

STEP (1)

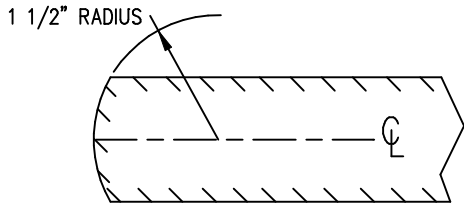

ROUND OFF EDGE OF DOOR AT PIVOT SIDE TO ALLOW FOR CLEARANCE.

STEP (2)

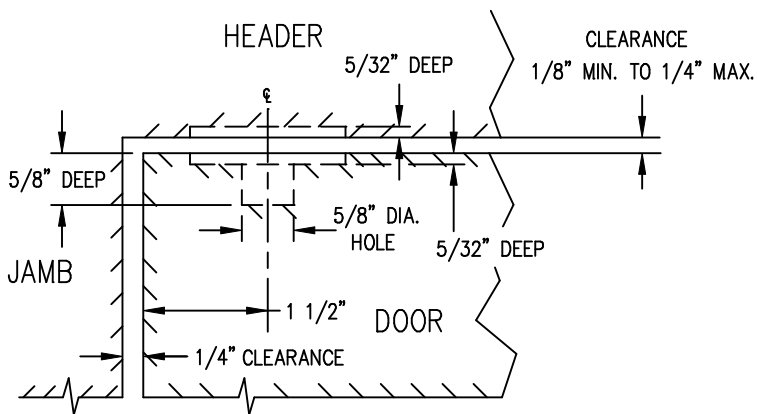
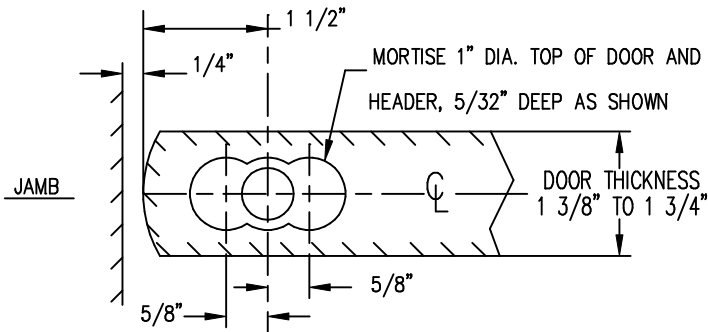

PREPARE 1" DIAMETER CUT OUT IN THE TOP OF THE DOOR AND HEADER.

INSTALL THE TOP PIVOT INTO THE HEADER AND MOUNT THE TOP PIVOT PLATE INTO THE TOP OF THE DOOR.

BOTH THE TOP PIVOT ASSEMBLY AND THE SPRING PIVOT IN THE BOTTOM OF THE DOOR MUST BE PLUMB AND ON THE SAME CENTERLINE.

STEP (3)

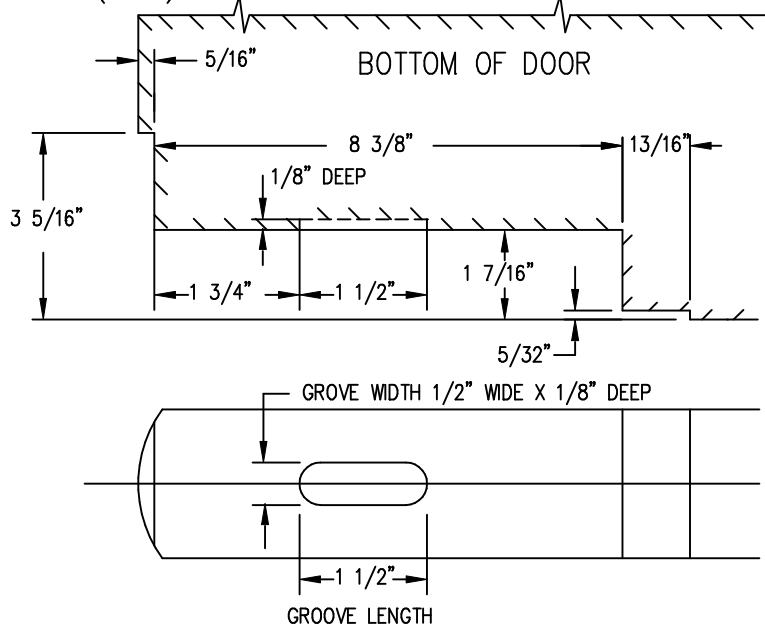

BOTTOM EDGE OF DOOR

PREPARE THE BOTTOM CORNER OF DOOR.

STEP (4)

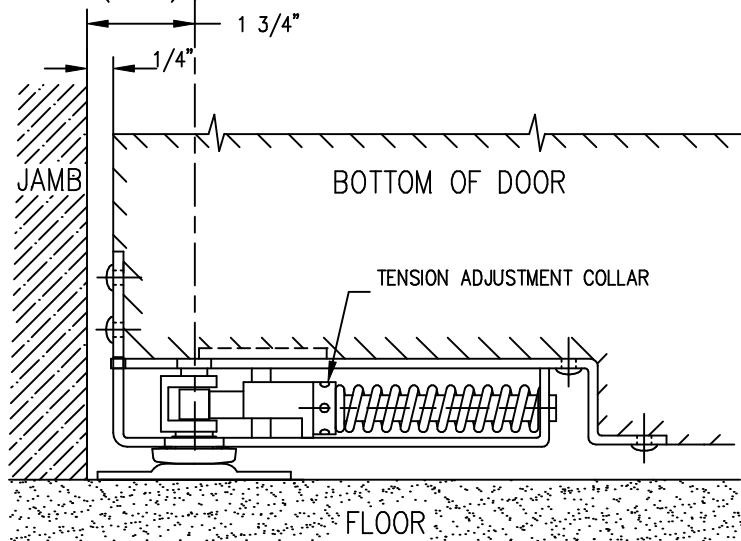

INSTALL THE SPRING PIVOT ASSEMBLY AS SHOWN.

STEP (5)

INSERT THE TOP PIVOT INTO THE TOP PIVOT PLATE.

SWING THE DOOR INTO PLACE AS SHOWN.

FASTEN THE FLOOR PLATE SECURELY TO THE FLOOR.

ADJUST SPRING TENSION BY TURNING TENSION COLLAR.

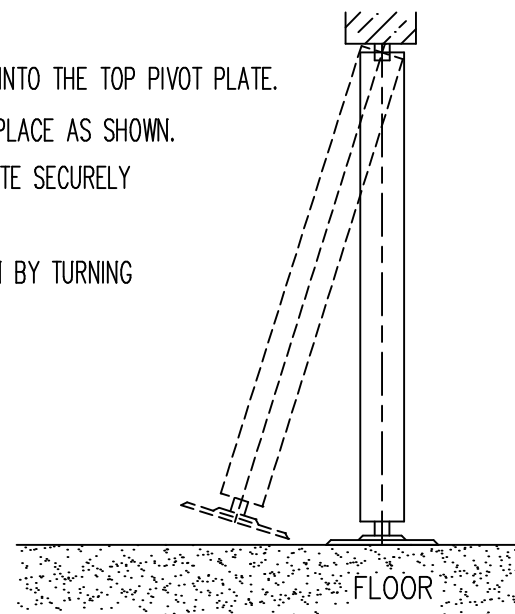

STEP (6)

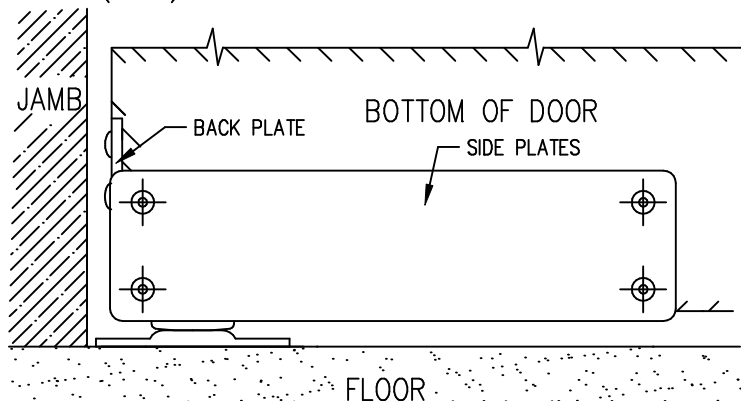

INSTALL SIDE PLATES AS SHOWN. (USE TOP HOLES IN SIDE PLATES ONLY)
ATTACH BACK PLATE.

BOMMER IND. INC.

LANDRUM, S.C.

INSTALLATION INSTRUCTIONS
DOUBLE ACTING HORIZONTAL SPRING PIVOT
PART NO.: 7813

Drawn by : JACKSON

DATE
15 SEP 03

SCALE
N.T.S.

DRAWING NUMBER
865682